

GIANT ATTACHMENTS

Here is a part of our wide range of attachments. The complete range of attachments can be found in the folder "attachments" or on our website.



WWW.GIANT-ATTACHMENTS.COM

Pictures may differ from actual product

WHEEL LOADERS

GIANT wheel loaders are totally designed and produced in own management in Oisterwijk (the Netherlands). In 2009 TOBROCO Machines has started with the development for new models for the existing range. These new models will replace the existing ones. For development TOBROCO Machines is using a sophisticated 3-dimentional design program. Thus before taken a machine in production, it's performance can be tested already. During the development of the new models TOBROCO takes care of the demands and needs of their customers. TOBROCO is a specialist in compact wheelloaders. In the modern plant in Holland they build the GIANT wheel loaders. We work with the best suppliers: Kubota, Rexroth. GIANT is robust, durable and quality made in Holland!

Also TOBROCO Machines offers you a very big variety of implements. The majority of these implements is designed and produced by TOBROCO Machines, and because of this, the implements are optimally adapted for your GIANT, which is more efficient this way.



TOBROCO

Industrielaan 2
5061 KC Oisterwijk
Tel.: +31 (0)13-5211212
Fax: +31 (0)13-5234045
Internet: www.tobroco.com
E-mail: info@tobroco.com



GIANT

Team **TOBROCO**
Industrielaan 2, 5061 KC Oisterwijk
Tel.: +31 (0)13-5211212
Fax: +31 (0)13-5234045
Internet: www.tobroco.com
E-Mail: info@tobroco.com



D267
D337T

WHEEL LOADERS

A flexible and compact jack of all trades



D267 - D337T

All technical data in this brochure refer to series models that have been tested under operating conditions typical of Central Europe and describe their standard functions. Specifications and their modes of functionality as well as accessories listed in this brochure depend on the individual model and on the options available with a particular product as well as the statutory requirements of the country of sale. Illustrations used in this brochure may show products that have not been mentioned or that are not available as series production machines. The descriptions, illustrations, weights and technical data published herein are non-binding in nature and represent the technical status at the time the document went to press. Because of ongoing development, we reserve the right to make changes, without prior notice, to the design, specification, visual appearance and technology of our products. Should you require special functions that would be available only by using additional components and/or under special circumstances, please feel free to contact us. We will be happy to answer any questions you may have and to provide further information regarding whether and under what conditions applying to the product and the target environment such special functions might be feasible. If you have any concerns about the load capacity or operation of our products in certain working conditions or environments, we recommend that you perform a test run under controlled conditions. Despite meticulous attention to detail, we cannot exclude the possibility that our products may not conform to illustrations or stated dimensions, or that errors may have occurred in calculation or during printing, or that the information given here may be incomplete. Consequently, we do not accept liability for the accuracy or completeness of the information supplied in this brochure. All matters relating to our product warranty are contained within our General Terms and Conditions. We expressly decline to provide additional guarantees. Any liability over and above that contained within our General Terms and Conditions is excluded.

P001300111 C-SERIES EN V214

WHEEL LOADERS

To full fill the needs and demands of her customers TOBROCO offers a wide range of wheel loaders. This range consists out of 25 different types of loaders with a service weight between 1000 kg and 4150 kg. In this leaflet, we will show you the range of GIANT's with a service weight of 2000 kg to 2100 kg. For further information about other types and implements we refer to our other leaflets or our website (www.tobroco.com).

TECHNICAL DATA



D267 - D337T

These mini wheel loaders are equipped with Kubota diesel engines. With 26 and 33 HP. The machines are equipped with a Bosch Rexroth automotive hydraulic pump which contributes to very smooth and powerful driving characteristics. Heavy axles, four-wheel drive, mechanical driveshaft, and an automatic differential lock mode ensure that the machine can use its power for maximum results. Strong pivoting articulation, all wheels at all time in contact with the ground and the machine moves with maximum traction.

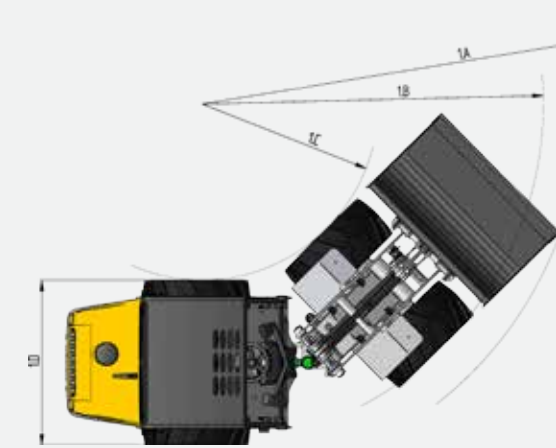
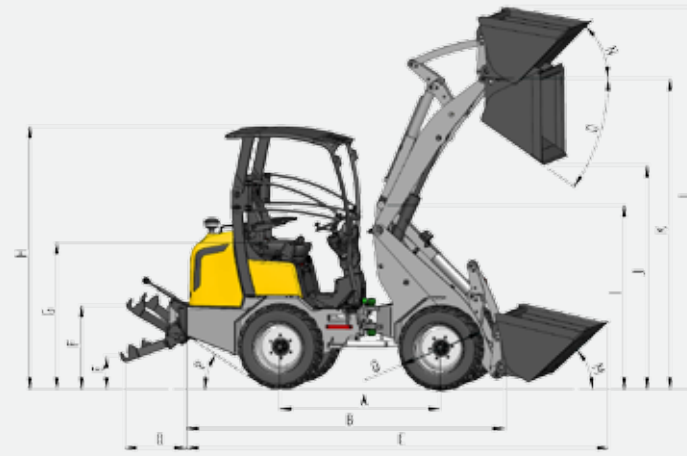

The GIANT wheel loaders are equipped with the latest Kubota diesel engines. Which meet the latest emission requirements. The engines are cleaner and have less CO2 emissions. Standard machines are fitted with large water and oil coolers. The engines are mounted on specially designed silent blocks so that vibration and noise level are reduced to a minimum. In order to increase the comfort GIANT wheel loaders have silent blocks under the driver's platform. With a luxury suspension seat with arm and headrest. This machine gives the luxury that every driver want. With the standard hydraulic quick-change system is the connecting and disconnecting of the attachments very easy.



10.0/75-15.3 AS (76x26 cm)
104 cm machine width

31x15.5-15 AS (76x37 cm)
128 cm machine width



31x15.5-15 TR-06 (76x37 cm)
128 cm machine width

31x15.5-15 Skid (79x40 cm)
131 cm machine width

	D267	D337T
Engine	3 cyl. Kubota 26 hp / 19 kW	3 cyl. Kubota turbo 33 hp / 24 kW
Service weight	2000 kg	2100 kg
Driving hyd.	Hydrostatisch automotiv	Hydrostatisch automotiv
Driving speed	0-12km/h	0-18 km/h
Driving mech.	Standard axles	Standard axles
Differential lock	Automatic both axles	Automatic both axles
Standard tyres	10.0/75-15.3 AS	10.0/75-15.3 AS
Service brake	Hydraulic	Hydraulic
Parking brake	Drumbrakes	Drumbrakes
Attachment bracket	GIANT Standard Hydraulic	GIANT Standard Hydraulic
Working hydraulics	45 L/min (180 bar)	45 L/min (190 bar)
Lifting capacity	1600 kg	1650 kg
Tipping load straight	1400 kg	1450 kg

	D267	D337T
A Wheel base	1524	1524
B Total lenght without bucket	2986	2986
C Total lenght with bucket	3700	3700
D Lenght 3-point lifting arm (option)	622	622
E Min height 3 point hitch	134	134
F Max. height 3 point hitch	797	797
G Seat height	1256	1256
H Max. height with ROPS/FOPS safetyroof	2300	2300
Max. height with cabin	2284	2284
Max. Foldable roof (up)	2348	2348
Max. Foldable roof (down)	1970	1970
I Height frontframe	1480	1480
J Max. dump bucket	1988	1988

	D267	D337T
K Max. bucket pin height	2825	2825
max. bucket pin height extended lift arm	2920	2920
L Height with bucket	3392	3392
M Roll back angle ground level	43°	43°
N Roll back angle	53°	53°
O Max. dump angle	47°	47°
P Max. drive angle	29°	29°
Q Diameter standaard tyre	760	760
1A Maximum radius	2635	2635
1B Outer turning radius	2257	2257
1C Inner turning radius	1021	1021
1D Width	1040	1040

	D267	D337T
S	1430 kg	1450 kg
T	1220 kg	1250 kg
U	910 kg	950 kg
U (extended lifting arm)	840 kg	880 kg
V	705 kg	745 kg
W	1975 kg	2000 kg
X	1250 kg	1270 kg
Y	970 kg	1000 kg

Tippingload in straight position, without extra counterweights. Data subject to change.



Hydraulic quick change GIANT, 3e hydr. Function, width range of attachments designed and produced by TOBROCO.

Rops/Fops safety roof, comfortable suspension seat with armrests and headrest. Driving platform on Rubber suspension silent blocks.

Cyclone filter standard, big kombi-cooler (oil and water) 2 big hydraulic oil tanks, modern Kubota engine.